

## ElectroStatic Discharged Protection Devices (ESD) Data Sheet

### Description

The UAD8A05L01-IP5 includes back-to-back TVS diodes fabricated in a proprietary silicon avalanche technology to provide protection for electronic equipment that may experience destructive electrostatic discharge (ESD). These robust diodes can safely absorb repetitive ESD strikes up to the maximum level specified in the IEC61000-4-2 international standard without performance degradation. The back-to-back configuration provides symmetrical ESD protection for data lines when AC signals are present.



### Features

- IEC61000-4-2 ESD 15KV Air, 8KV contact compliance
- SOD882 surface mount package
- Working voltage: 5V
- Low leakage current
- Low operating and clamping voltages
- Lead Free/RoHS compliant
- Flammability rating UL 94V-0
- Meets MSL level 1, per J-STD-020
- Marking: U5

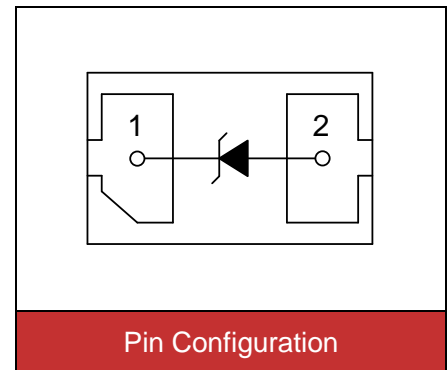

### Applications

- USB 3.0/USB 2.0
- MHL/MIPI/MDDI
- HDMI, Video Port, eSATA
- Set Top Boxes, Game Consoles
- Smart Phones
- External Storage
- Ultrabooks, Notebooks
- Tablets, eReaders

### Maximum Ratings

Rating	Symbol	Value	Unit
ESD voltage (Contact discharge)	$V_{ESD}$	$\pm 8$	kV
ESD voltage (Air discharge)		$\pm 15$	
Storage & operating temperature range	$T_{STG}, T_J$	-55~+150	°C

**Electrical Characteristics (T<sub>J</sub>=25°C)**

Parameter	Symbol	Condition	Min.	Typ.	Max.	Unit
Reverse stand-off voltage	V <sub>RWM</sub>				5	V
Reverse breakdown voltage	V <sub>BR</sub>	I <sub>BR</sub> =1mA	6		8.5	V
Reverse leakage current	I <sub>R</sub>	V <sub>R</sub> =5V			1	μA
Clamping voltage (tp=8/20μs)	V <sub>C</sub>	I <sub>PP</sub> =1A			9.8	V
Clamping voltage (tp=8/20μs)	V <sub>C</sub>	I <sub>PP</sub> =4A			15	V
Peak pulse current (tp=8/20μs)	I <sub>PP</sub>				5	A
Clamping voltage TLP (Note1)	V <sub>C</sub>	16A		24		V
Off state junction capacitance	C <sub>J</sub>	0Vdc,f=1MHz		0.6		pF

Note1. Electrostatic Discharge Sensitivity Testing using Transmission Line Pulse(TLP) Model, See Figure 4.

**Typical Characteristics Curves**

Figure 1. Pulse Waveform

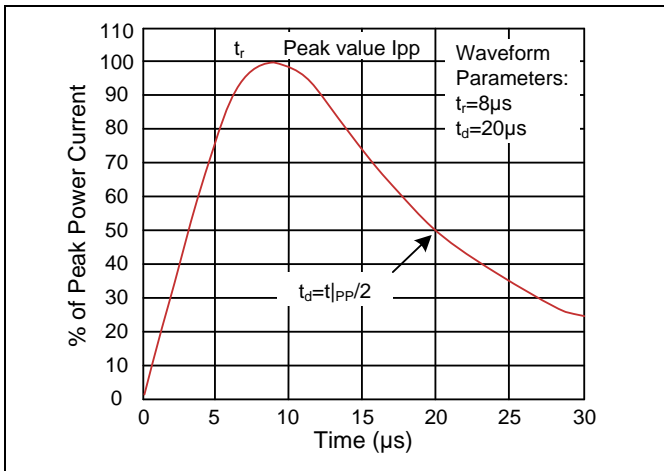

Figure 2. Clamping Voltage vs. Peak Pulse Current

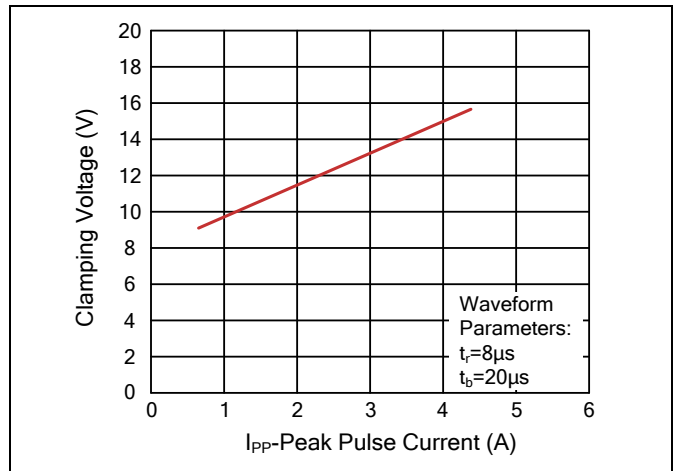

Figure 3. Capacitance vs. Reverse Voltage

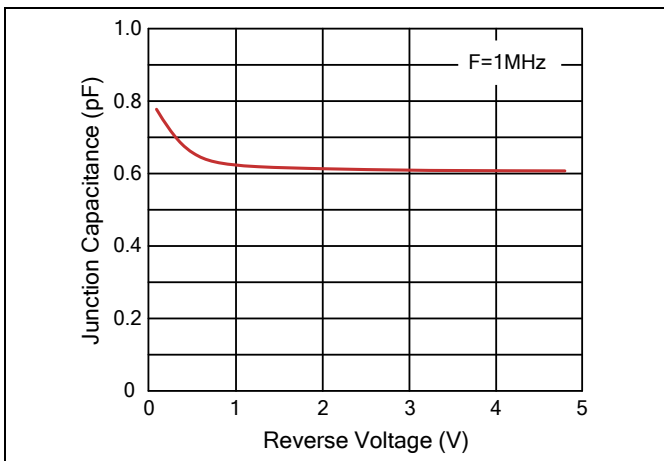
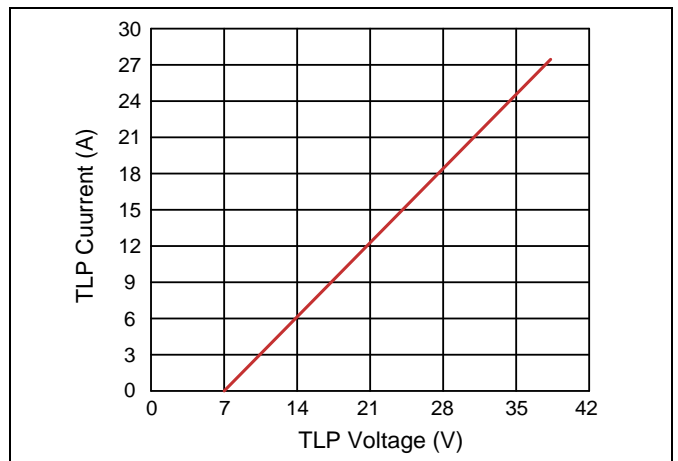
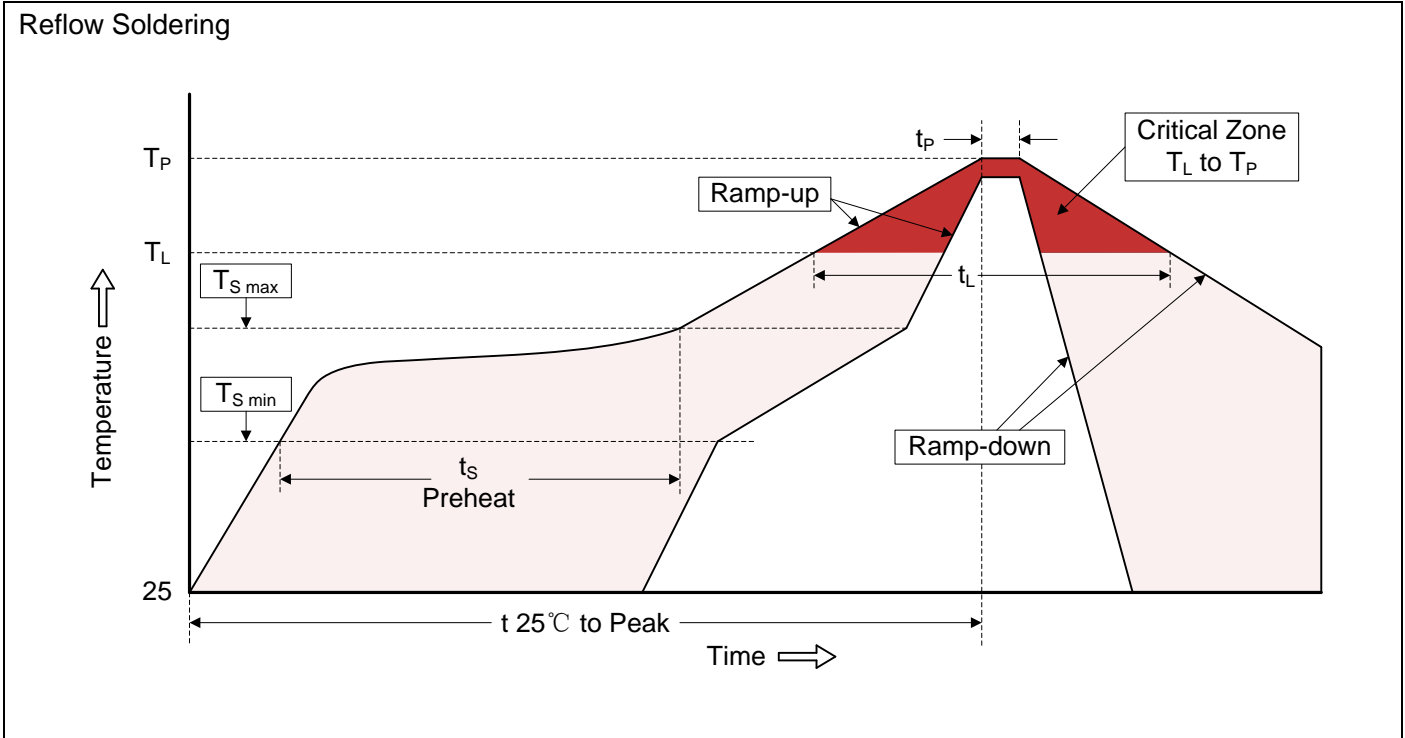

Figure 4. Transmission Line Pulsing (TLP)



**Recommended Soldering Conditions**



**Recommended Conditions**

Profile Feature	Pb-Free Assembly
Average ramp-up rate ( $T_L$ to $T_P$ )	3°C/second max.
Preheat -Temperature Min ( $T_{S\ min}$ ) -Temperature Max ( $T_{S\ max}$ ) -Time (min to max) ( $t_s$ )	150°C 200°C 60-180 seconds
$T_{S\ max}$ to $T_L$ -Ramp-up Rate	3°C/second max.
Time maintained above: -Temperature ( $T_L$ ) -Time ( $t_L$ )	217°C 60-150 seconds
Peak Temperature ( $T_P$ )	260°C
Time within 5°C of actual Peak Temperature ( $t_P$ )	20-40 seconds
Ramp-down Rate	6°C/second max.
Time 25°C to Peak Temperature	8 minutes max.

**Dimensions (SOD882)**

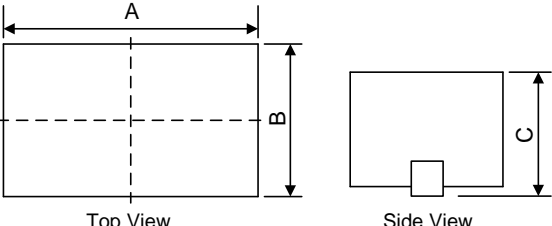
 <p>Top View</p> <p>Side View</p>	Dimension (mm)			
	Millimeters		Inches	
Symbol	Min.	Max.	Min.	Max.
A	0.95	1.05	0.037	0.041
B	0.55	0.65	0.022	0.026
C	0.32	0.55	0.013	0.022
D	0.65 BSC		0.026 BSC	
E	0.20	0.30	0.008	0.012
F	0.45	0.55	0.018	0.022

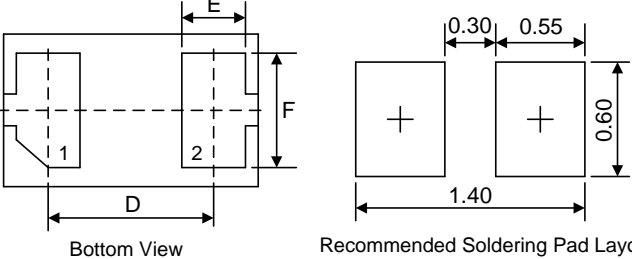

 <p>Bottom View</p> <p>Recommended Soldering Pad Layout</p>
--

**Packaging**

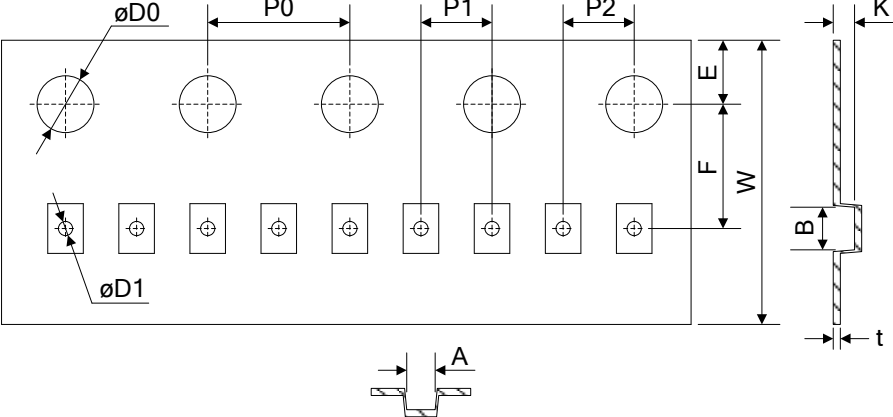
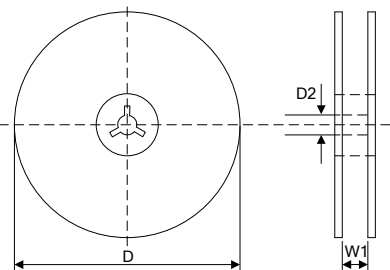
<p>Tape</p> 	Symbol	Dimension (mm)
	W	8.00±0.30
	P0	4.00±0.10
	P1	2.00±0.10
	P2	2.00±0.10
	D0	Φ1.55±0.10
	D1	Φ0.40±0.05
	E	1.75±0.10
	F	3.50±0.10
	A	0.75±0.10
	B	1.15±0.10
	K	0.60±0.05
	t	0.20±0.05

<p>Reel</p> 	D	Φ178.0±2.0
	D2	Φ13.00.
	W1	9.50
	Quantity: 10000PCS	